

LINED TEES

EQUAL TEE

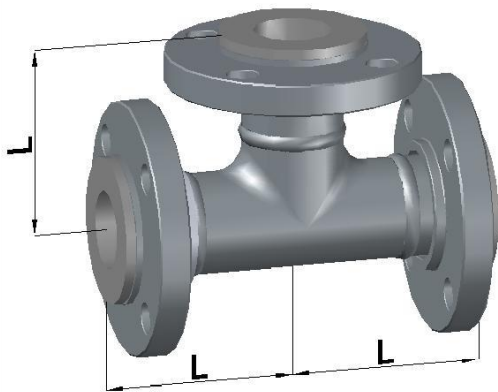

| NB #150 | L mm | Wt kg |
|------------|---------|----------|
| ½" | 65 | 1.6 |
| ¾" | 75 | 2.2 |
| 1" | 89 | 3.5 |
| 1.5" | 102 | 5.9 |
| 2" | 114 | 9.2 |
| 3" | 140 | 17.9 |
| 4" | 165 | 26.1 |
| 6" | 203 | 41.7 |
| 8" | 229 | 68.8 |
| 10" | 279 | 96.8 |
| 12" | 305 | 132 |

BLOWN EQUAL TEE

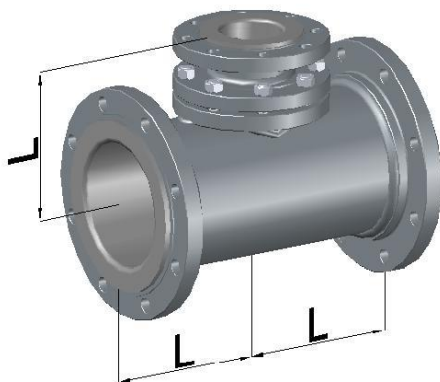

| NB1 #150 | NB2 #150 | L mm | Wt kg |
|-------------|-------------|---------|----------|
| ¾" | ½" | 75 | 2.0 |
| 1" | ½" | 89 | 2.9 |
| 1" | ¾" | 89 | 3.1 |
| 1½" | ½" | 102 | 4.6 |
| 1½" | ¾" | 102 | 4.8 |
| 1½" | 1" | 102 | 5.2 |
| 2" | ½" | 114 | 6.8 |
| 2" | ¾" | 114 | 7.0 |
| 2" | 1" | 114 | 7.4 |
| 2" | 1½" | 114 | 8.2 |
| 3" | 1" | 140 | 13.5 |
| 3" | 1½" | 140 | 14.3 |
| 3" | 2" | 140 | 15.4 |
| 4" | 1" | 165 | 19.3 |
| 4" | 1½" | 165 | 20.2 |
| 4" | 2" | 165 | 21.2 |
| 4" | 3" | 165 | 23.9 |
| 6" | 1" | 203 | 30.8 |
| 6" | 1½" | 203 | 31.7 |
| 6" | 2" | 203 | 32.8 |
| 6" | 3" | 203 | 35.6 |
| 6" | 4" | 203 | 37.9 |
| 8" | 1" | 229 | 50.7 |
| 8" | 1½" | 229 | 51.6 |
| 8" | 2" | 229 | 52.7 |
| 8" | 3" | 229 | 55.5 |
| 8" | 4" | 229 | 57.8 |
| 8" | 6" | 229 | 61.7 |
| 10" | 4" | 279 | 78.8 |
| 10" | 6" | 279 | 83.0 |
| 10" | 8" | 279 | 90.6 |
| 12" | 4" | 305 | 104 |
| 12" | 6" | 305 | 108 |
| 12" | 8" | 305 | 115 |
| 12" | 10" | 305 | 122 |

REDUCING TEE



Picture for illustration only, type of steel fabrication varies